

DH-PFB7716WA-SG-EX

Anti-corrosion Wall Mount Bracket



- Crafted from aluminum alloy, the wall mount bracket is highly corrosion-resistant and designed to support loads of up to 6 kg.
- Compatible with the DH-IPC-HFEXXXF series.



Series Overview

Dahua Mounting Bracket works with front-end services, supporting installation methods such as wall mount, pole mount, corner mount and in-ceiling mount. Select brackets are designed to suit complex scenes, making them convenient to use in environments with high temperatures, humidity, frequent vibrations, and in locations that are highly corrosive. These highly reliable brackets are easy to install and use

Scene

Ideal for mounting cameras, and works in temperatures ranging from $-40\text{ }^{\circ}\text{C}$ to $+60\text{ }^{\circ}\text{C}$ ($-40\text{ }^{\circ}\text{F}$ to $+140\text{ }^{\circ}\text{F}$) and in environments with a relative humidity of less than 90%.

Technical Specification

Camera	
Casing Material	ADC12
Product Dimensions	111.5 mm × 102 mm × 88 mm (4.39" × 4.02" × 3.46") (L × W × H)
Appearance Color	Silver Grey
Net Weight	1.1 kg (2.43 lb)
Gross Weight	1.4 kg (3.09 lb) (single package)
Load Bearing	6 kg (13.23 lb)
Installation	Wall mount
Applicable Model	DH-IPC-HFEXXXF Series
Packaging Dimensions	185 mm × 150 mm × 445 mm (7.28" × 5.91" × 17.52") (L × W × H)
Environment	
Operating Temperature	$-40\text{ }^{\circ}\text{C}$ to $+60\text{ }^{\circ}\text{C}$ ($-40\text{ }^{\circ}\text{F}$ to $+140\text{ }^{\circ}\text{F}$)
Operating Humidity	10%–90% (RH), non-condensing
Storage Temperature	$-30\text{ }^{\circ}\text{C}$ to $+70\text{ }^{\circ}\text{C}$ ($-22\text{ }^{\circ}\text{F}$ to $+158\text{ }^{\circ}\text{F}$)
Storage Humidity	<95% (RH), non-condensing
Anti-corrosion Level	Moderate Protection *The products feature high-grade anti-corrosion protection, making them well-suited for environments with standard corrosion resistance requirements. They perform reliably from 2 km (1.24 mi) and above in coastal areas and in locations prone to acid rain exposure.

Ordering Information

Type	Model	Description
Camera Mount	DH-PFB7716WA-SG-EX	Anti-corrosion Wall Mount Bracket

Installation

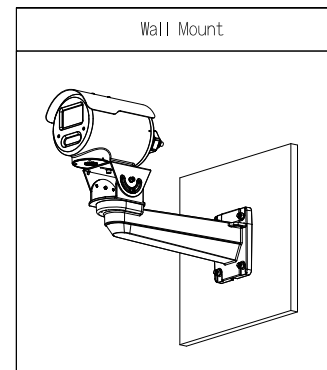

Dimensions (mm[inch])

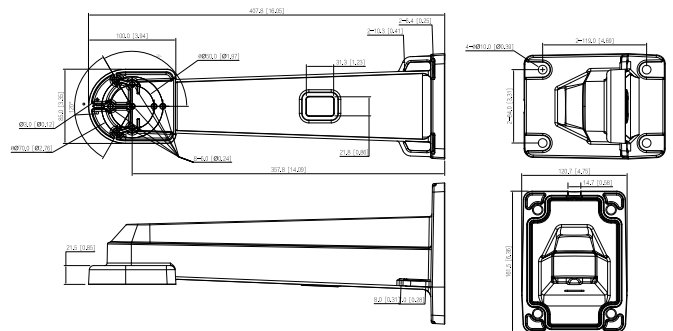

Package Information

- M6 × 14 outer hexagonal screws × 4
- M8 × 80 countersink screws × 4
- Nuts × 4
- Spring washers × 4
- Flat gaskets × 4
- Expansion tubes × 4

Rev 002.000 © 2024 Dahua. All rights reserved. Design and specifications are subject to change without notice. The images, specifications and information mentioned in the document are only for reference, and might differ from the actual product.