

CUSTOMER NAME : 0306

SPECIFICATION FOR APPROVAL

ITEM : DC Voltage Stabilized Supply

MODEL NO. : ADS-110DL-48N-1 530096E

SAMPLE CODE: 0306DL53V1.812AE REV.: A11

SAMPLE P/N : 911003069911211R No.: S18/0458

CUSTOMER CODE_NO. : 1.2.19.07.10227

CUSTOMER'S APPROVED

Please send one copy of this specification back after you signed approval for production pre-arrangement.

Approved By : _____

Date : _____

Drawing	Agreement				Approver
	Product Eng.	Mechanical	PM	Check	
冯晓玲	郝嵬敏	吴小东	孙芬芬	周和康	郝留全
Feb.23.2023	Feb.23.2023	Feb.23.2023	Feb.23.2023	Feb.23.2023	Feb.23.2023

SHENZHEN HONOR ELECTRONIC CO.,LTD

Address: Xinghui Industrial Park, Gushu No.2 Road, Xixiang Town, Shenzhen, Guangdong, China.

Telephone:86-755-3385-7182

Telefax: +86-755-81453432

Http://www.honor-cn.com

Table Of Contents

	Page
1. Revision History.....	5-7
2. Electrical Specification	8~15
2-1. General Specification.....	9
2-2. Electrical Requirements.....	9
2-2-1. Input Voltage.....	9
2-2-1-1. Input Voltages.....	9
2-2-1-2. Inrush Current(Cold Start).....	9
2-2-1-3. Input Fuse.....	9
2-2-1-4. Input Current.....	9
2-2-1-5. Frequency.....	9
2-2-1-6. Efficiency.....	9
2-2-1-7. Primary Over Current Protection.....	9
2-2-1-8. Power loss (Minimum Load Power Consumption).....	10
2-2-1-9. Input Configuration.....	10
2-2-2. Output Requirements.....	10~11
2-2-2-1. Maximum output power.....	10
2-2-2-2. Output Voltage and Current.....	10
2-2-2-3. Output Load Regulation.....	10
2-2-2-4. Ripple and Noise.....	10
2-2-2-5. Line Regulation.....	10~11
2-2-2-6. Hold up time.....	11
2-2-2-7. Turn On delay time.....	11
2-2-2-8. Rise time.....	11
2-2-2-9. Overshoot	11
2-2-2-10. Dynamic Load Response.....	11
2-3. Protection Requirements.....	11
2-3-1. Over current protection.....	11
2-3-2. Short Circuit Protection(Auto recovery).....	11
2-3-3. Over Voltage Protection	11
2-3-4. Over temperature protection	11

Table Of Contents

	Page
2-4. Safety and EMC Requirement.....	12~13
2-4-1. Earth Leakage Current.....	12
2-4-2. Hi-Pot tests (Dielectric withstand voltage).....	12
2-4-3. Insulation Resistance.....	12
2-4-4. RFI/EMI/EMS Standards.....	12
2-4-5. EMS Standards.....	12
2-4-5-1. Electrostatic Discharge ESD.....	12
2-4-5-2. Radiated Immunity RS.....	12
2-4-5-3. EFT.....	12~13
2-4-5-4. Conducted Radio Frequency.....	13
2-4-5-5. Lightning Surge	13
2-4-6. Safety Standards.....	13
2-4-7. EMI.....	13
2-5. Reliability requirement.....	13~14
2-5-1. Mean Time between Failures (MTBF).....	13
2-5-2. E-CAP Lifetime.....	14
2-5-3. Drop Test.....	14
2-5-4. Random vibration test (non-operating).....	14
2-5-5. Hearing Noise.....	14
2-5-6. Hot Burn-In.....	14
2-6. Environment Requirements.....	14~15
2-6-1. Operating temperature.....	14
2-6-2. Operating humidity.....	14
2-6-3. Storage temperature.....	15
2-6-4. Storage humidity.....	15
2-6-5. Operation Altitude.....	15
2-7. Mechanical Features.....	15
2-7-1. Physical size.....	15
2-7-2. AC Input Connector.....	15
2-7-3. Output plug.....	15
2-7-4. LED Light.....	15

Table Of Contents

	Page
2-7-5. Weight.....	15
2-7-6. Case Color.....	15
3. Circuit Drawing.....	16~17
4.PCB.....	18~19
4-1.TOP SILK.....	19
4-2.BOTTOM SILK.....	19
5.Mechanical Specification.....	20~25
5-1. Case.....	21
5-2. Cable Drawing.....	22
5-3. Label Drawing.....	23
5-4. Barcode Label.....	24
5-5. Packing Drawing.....	25

1.Revision History

NO.	Date	Revision History	Rev.	Page
1	Apr.17.2018	~1st sample	A0	
2	Apr.25.2018	Add customer P/N, update sch, barcode.	A1	
3	May.12.2018	Update label(add 3C, PSE, KC, EAC mark).	A2	
4	Jun.07.2018	Update label(add BIS mark).	A3	
5	Sep.18.2018	Update label (add BIS mark Website).	A4	
6	Dec.22.2019	Update label (add power)	A5	
7	Oct.23.2020	Update label (add argentina mark).	A6	
8	Mar.05.2021	Add UKCA mark on the label.	A7	
9	Jun.18.2022	Update packing.	A8	
10	Jul.13.2022	Update label(add the SAA certificate number).	A9	
11	Sep.16.2022	Update customer P/N, label(change the PSE importer to MOTHERTOOL CO.,LTD).	A10	
12	Feb.23.2023	Upgraded CCC, updated honor P/N, varistor from 10D561 to 10D621, update customer P/N, label(change the PSE importer to MITSUBOSHI DIAMOND INDUSTRIAL CO.,LTD).	A11	

CHANGE ITEM

Before (Rev.)	After (Rev.)	Change Reason	Remark

2. Electrical Specification

2-1. General Spec

Product Description

: This Specification defines the input, output, performance characteristics, environment, noise and safety requirements for power supply.

Parameter Specification

: Unless specification otherwise, all parameters must meet over the limit of temperature, load, and input voltage.

: All measurements shall be taken at $25^{\circ}\text{C}\pm 5^{\circ}\text{C}$ ambient unless otherwise noted.

2-2. Electrical Requirements

2-2-1. Input Voltage

2-2-1-1. Input Voltages

Normal voltage: 100 to 240VACrms

Voltage range: 90 to 264VACrms

2-2-1-2. Inrush Current(Cold Start)

Inrush current should be lower than 50/80 A under cold start and 1st half cycle of 115/230 Vrms input voltage.

2-2-1-3. Input Fuse

The input fuse shall not blow up.

2-2-1-4. Input Current

$\leq 1.5\text{Arms}$ at 100 to 240Vac input and full load.

2-2-1-5. Frequency

Normal frequency :50Hz - 60Hz

Frequency range :47Hz - 63Hz

2-2-1-6. Efficiency

The average efficiency shall not be less than 88.00%(Expressions:[$49\text{W} < P_o \leq 250\text{W}; \geq 0.88$])

- According to Energy star standard DoE VI.
- Both 115Vac(60Hz) and 230Vac(50Hz) input voltage condition.
- Average (25%+50%+75%+100%)/4
- The DC power supply shall be operated at 100% of nameplate current output for at least 30 minutes immediately prior to conducting

2-2-1-7. Primary Over Current Protection

An adequate internal fuse on the AC input line shall be provided.

2-2-1-8.Power Loss (Minimum Load Power Consumption)

CONDITION		RESULT(SPEC)
INPUT VOLTAGE	230VAC	0.21W MAX (INPUT POWER)
OUTPUT VOLTAGE	+53.0V / No Load	AT 230Vac/50Hz

2-2-1-9.Input Configuration

3 Conductors(Live, Neutral, Earth)

2-2-2.Output Requirements
2-2-2-1.Maximum Output Power: 101.50Watts
2-2-2-2.Output Voltage and Current

OUTPUT VOLTAGE	MINIMUM VOLTAGE	MAXIMUM VOLTAGE	OUTPUT CURRENT	INPUT VOLTAGE
+53.00VDC	+53.00VDC	+56.00VDC	0.00A~1.812A	100Vac-240Vac

table 1

2-2-2-3.Output Load Regulation

The output voltage regulation shall meet above table 1, including the effects of line voltage variations, load current, ripple and noise, and the AC component of the load current . The effect of dynamic load changes is not included in this limit.

2-2-2-4.Ripple and Noise

A	B(Input Voltage 115Vac to 230Vac)
53.0Vdc	0.35Vp-p(350mV)

Column A : Output Voltage

Column B: AC Input + Switching Ripple and Noise

Measured methods:

- 1.Performed by 20M Hz bandwidth in oscilloscope.
- 2.Applied 0.1uF high frequency capacitor and 47uF electrolytic capacitor across the end of DC cable.
- 3.Measured at the end of DC cable.
- 4.Tested at 115Vac(60Hz) and 230Vac(50Hz).

2-2-2-5.Line Regulation $\pm 2\%$

Line Regulation= $\Delta V/V_{nor} \times 100\%$ $\Delta V: V_{max}-V_{nor}$ or $V_{min}-V_{nor}$

Note: V_{max} :The maximum output voltage when the input voltage changes;

V_{min} :The Minimum output voltage when the input voltage changes;

V_{nor} :Rated output voltage.

2-2-2-6.Hold Up Time

10mS min.@115VAC input and full load

20mS min.@230VAC input and full load

2-2-2-7.Turn On Delay Time

3S max@ 100Vac to 240Vac input and output Max.Load.

2-2-2-8.Rise Time

DC output rise time from 10% to 90% of output voltage shall be less than

30mS @100Vac to 240Vac input and output Max.Load.

2-2-2-9.Overshoot

The output overshoot at turn-on shall not exceed +10%(V) of output voltage at no load and full load connected.

2-2-2-10.Dynamic Load Response

Condition:load step from 0 to 100%, transient voltage: 52V-57V,5Vp-p;

20% to 80%,transient voltage: 53V-57V,4Vp-p; 0 to 50%, transient voltage: 53V-56V,3Vp-p;

50% to 100%,transient voltage: 53V-56V,3Vp-p; 50% to 75%,transient voltage: 53V-56V,3Vp-p;

0 to 25%,transient voltage: 53V-56V,3Vp-p;

R/S: 1.0A/uS Transient Response Recovery Time : $\leq 30\text{mS}$

2-3. Protection Requirements**2-3-1.Over Current Protection**

2.2A-3.8A @input 90~264Vac 50/60 Hz

2-3-2.Short Circuit Protection

The input power shall decrease when the DC output "+" and "-" short, the power supply shall no damage,and shall be self-recovery when the fault condition is removed.

2-3-3.Over Voltage Protection

OVP: 63V Max

2-3-4.Over temperature protection

When operating any output under any line condition, into a over temperature condition for any indefinite period of time, the power supply shall be self – recovering when fault condition remove.

2-4. Safety and EMC Requirements

2-4-1. Earth Leakage Current.

3.50mA Max (264V, 50Hz)

2-4-2. Hi-Pot test

1). Hi-Pot test (Dielectric withstand voltage)-CLASS II

: leakage(cutoff) current 10mA

: Safety Standard Condition:

Primary To Secondary : 3000Vac , 1 minute for type test

: Mass Production Condition:

Primary To Secondary : 3600Vac , keeping 2 seconds for production

* Test methods: Input test voltage beginning from zero to 3600Vac in 0.5s. We move plug after discharge display 0V.

* Test point : Primary Live and Natural Short ↔ Secondary

2). Hi-Pot test (Dielectric withstand voltage)-CLASS I

: leakage(cutoff) current 10mA

: Safety Standard Condition:

Primary To GND : 1500Vac , 1 minute for type test

Primary To Secondary : 3000Vac , 1 minute for type test

: Mass Production Condition:

Primary To GND : 1800Vac , keeping 2 seconds for production

Primary To Secondary : 3600Vac , keeping 2 seconds for production

* Test methods: Input test voltage beginning from zero to 3600Vac in 0.5s. We move plug after discharge display 0V.

* Test point : Primary Live and Natural Short ↔ Ground

2-4-3. Insulation Resistance

Insulation resistance shall be more than 100MΩ at 500Vdc between primary live, primary neutral and secondary.

2-4-4. RFI/EMI/EMC Standards

The adapter shall comply with a following RFI/EMI standards when tested in an system configuration.

2-4-5. EMS Standards

2-4-5-1. EN61000-4-2(IEC61000-4-2:2001 IEC801-2): Electrostatic Discharge ESD

Electrostatic Discharge: ±15 KV(Air) ±8 KV(Contact)

2-4-5-2. EN61000-4-3(IEC61000-4-3:2002 IEC801-3): Radiated Immunity RS

Radiated Susceptibility: 3V/m

2-4-5-3. EN61000-4-4(IEC61000-4-4:1995+A1:2000+ A2:2001 IEC801-4): EFT

Transient Test: ± 1 KV(EFT)

2-4-5-4.EN61000-4-6(IEC61000-4-6:1996+A1:2000)Conducted Radio Frequency

Injected Current Susceptibility:3Vrms

2-4-5-5.LightningSurge

The power supply must satisfy Table's LightningSurge Spec.

Products	Test Voltage	Test Point & Test Mode	Output Load
Adapter	± 2 KV	Line to Line : C-Mode	Rated Load
	± 4 KV	Line to Gnd : CR-Mode	

Measured methods: a. Environment Requirements: temperature :15~35°C; humidity :10%~75%RH;

b.Surge voltage is applied to the phase: 0° 90° 180° 270°;

c.Surge voltage is applied: for each polarity voltage of each repeated 5 times, a phase done; 10 times,each applied voltage interval of 60 seconds.

2-4-6.Safety Standards

The adapter shall be certified with the following safety standards:

The adapter should be sold in the country(ies) certified and specified in this specification.

Type(Marking)	Country/Region	Situation	Standard
UL/CUL(OR CSA)	USA	certified	UL60950-1
	Canada		CAN/CSA C22.2 No.60950-1
FCC	USA	certified	ANSI C63.4-2003;FCC Part 15 ClassB
CE	Europe	certified	IEC/EN62368-1
CCC	China	certified	GB 4943.1-2022;GB/T 9254.1-2021;GB 17625.1-2012
EAC	Russia	certified	IEC 60950-1 :2015
BIS	India	certified	IS 13252
PSE	Japan	certified	J 60950;J 55022;J55013
RCM	Australia&New Zealand	certified	AS/NZS CISPR22;AS/NZS60950.1
KC Mark	Korea	certified	K60950-1;K00022;K00024
K-MEPS		certified	MKE's Notification 2008-99

2-4-7.EMI:-3dB margin(ClassB) QP

2-5. Reliability Requirement

2-5-1.Mean Time Between Failures (MTBF)

Output Voltage	Min Voltage	Max Voltage	Current	MTBF	Load Condition
+53.00V	+53Vdc	+56Vdc	1.812A	50,000Hr	100%

*Standard: TELCORDIA SR-332 issue 02 (2006)

*Environment temperature: 25°C

2-5-2.E-cap Lifetime

The life estimation of aluminum capacitor must achieve 30,000 hours at 25°C.

Standard: Life Time=Lr * 2^{(To-Tx)/10} * 2^{(ΔTo-ΔT)/5}

$$(\Delta T_o - \Delta T) / 5 = 1 - [I_a / (I_s * T_f * F_f)]^2$$

Note-3 CE Capacitor Life time ΔTo: Self Heat Coefficient (85°C =10, 105°C = 5)

Lr : Capacitor Life Spec Ia : Measured Ripple Current

To : Capacitor Temp Spec Is : Ripple Current spec

Tx : Capacitor case Temp Ff : Frequency Factor

ΔT : Capacitor Self Heat Tf : Temperature Factor

2-5-3.Drop Test

Unit shall survive drops on all 6 faces from a height of 1m onto hard wood (Total 1 times/face)

No surface crack, function are normal, can be passed dielectric strength and insulation resistance test.

Test bench requirements: 13mm thick hard wood glued in the middle of 19mm-20mm thick plywoods

2-5-4.Random Vibration Test (non-operating)

Vibrating Amplitude :1.5mm(Max.) ;Frequency range: from 10Hz to 55Hz, Constantime:10-55-10Hz (1 minute); Direction: vibration X, Y and Z-axis, at least 30 min/axis. Normal performance after test condition is removed.

2-5-5.Hearing Noise

The noise generated by the adapter supplied under 100-240Vac of no load and full load shall be lower than 30dBA,measure 5cm from the nameplate.

2-5-6.Hot Burn-In

Condition		Result(Spec)
Input Voltage	100Vac / 240Vac	NO Defect, Normal Operating
Output Current	80%~100% Load	
Temperature	40°C ± 5°C	
Test Time	4HR ± 1HR	

2-6.Environment Requirements

2-6-1.Operating Temperature

→ 0°C ~ 45 °C (-10°C~55°C no damage)

2-6-2.Operating Humidity

→ 10% ~ 90 % RH (Condensation : NOT REQUIRED)

2-6-3.Storage Temperature

→ -20°C ~ 80°C

2-6-4.Storage Humidity

→ 5% ~ 95 % RH (Condensation : NOT REQUIRED)

2-6-5.Operation Altitude

→ 0-5000m

2-7. Mechanical Features

2-7-1.Physical Size(Unit:mm):156.00(L)* 58.00(W)*33.50(H)

2-7-2.AC Input Connector: C14 INLET

2-7-3.Output Plug

DC Plug: straight Φ 6.5x1.35x10mm

DC Cable: 22AWG 2464 1.2m Black

2-7-4.LED Light:No

2-7-5.Weight : About 365g

2-7-6.Case Color: Black

3. Circuit Drawing

4. PCB Drawing

TOPSILK

Pictures as below just for reference, according with the latest PCB edition.

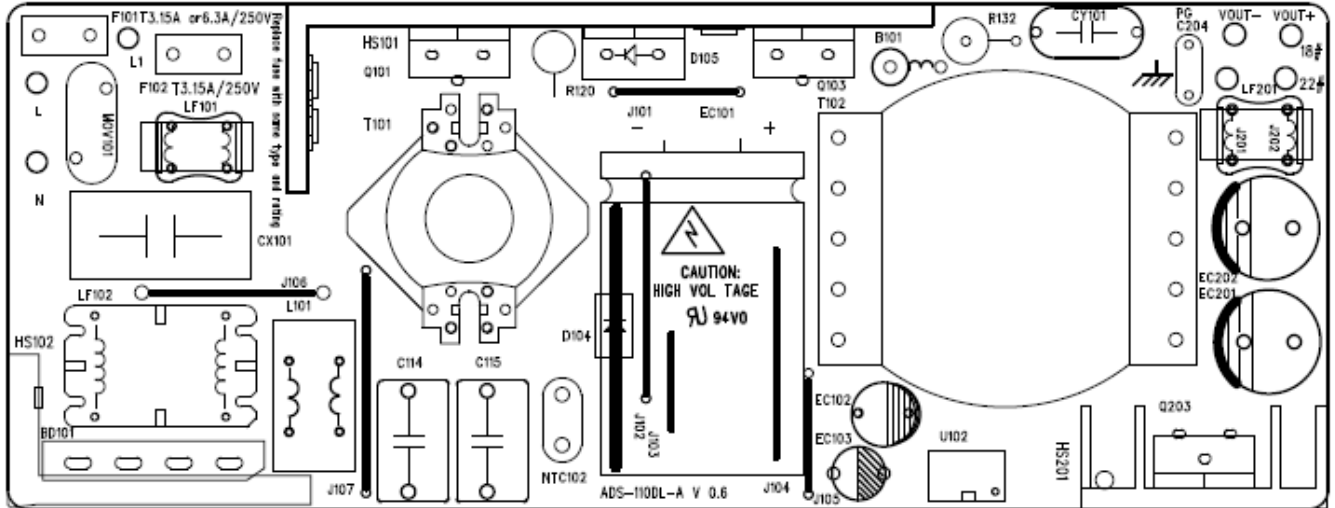

BOTTSILK

Pictures as below just for reference, according with the latest PCB edition.

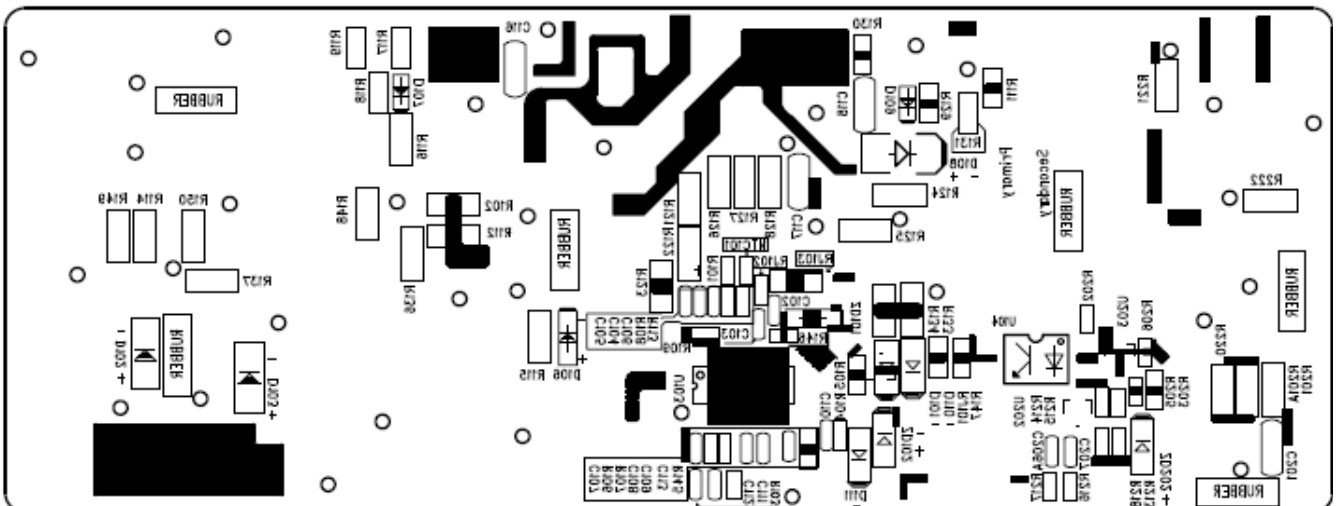

5. Mechanical Specification

5-1. Case Drawing

5-2. Cable Drawing

5-3. Label Drawing

5-4. Barcode Label

5-5. Packing Drawing

5-1. Case Drawing

Unit: mm

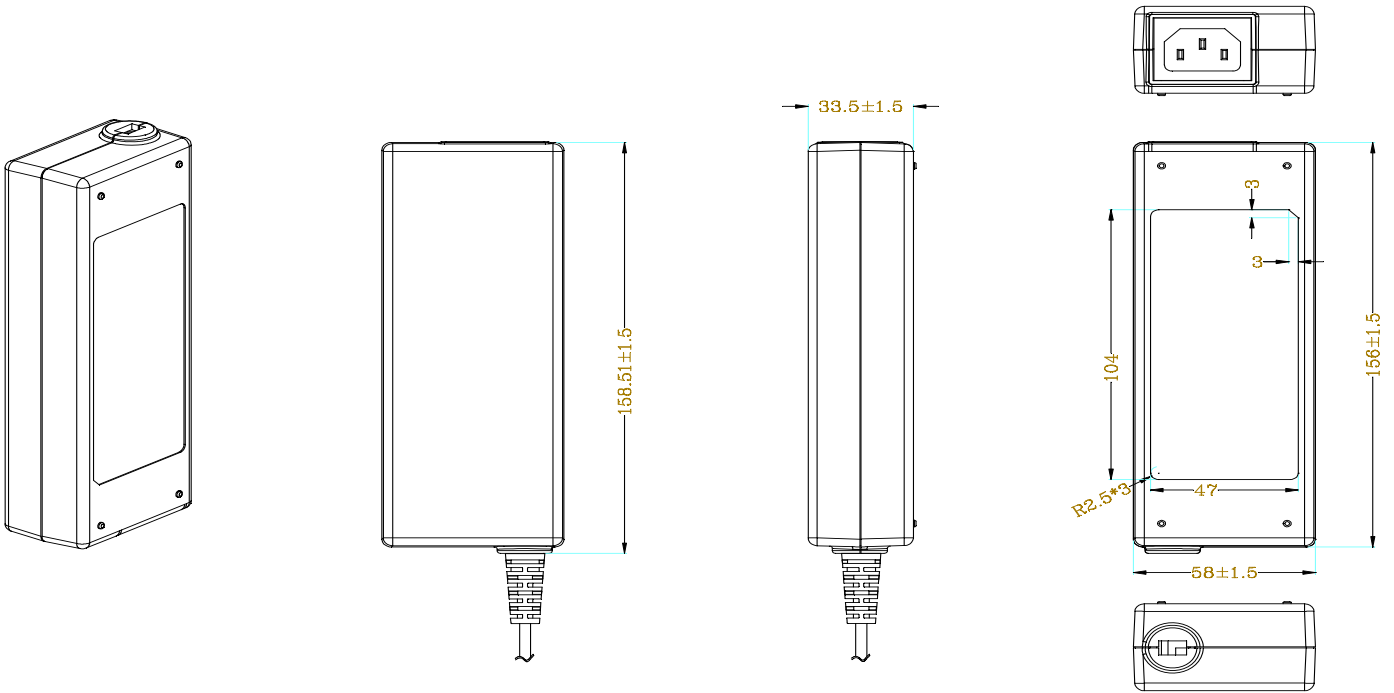

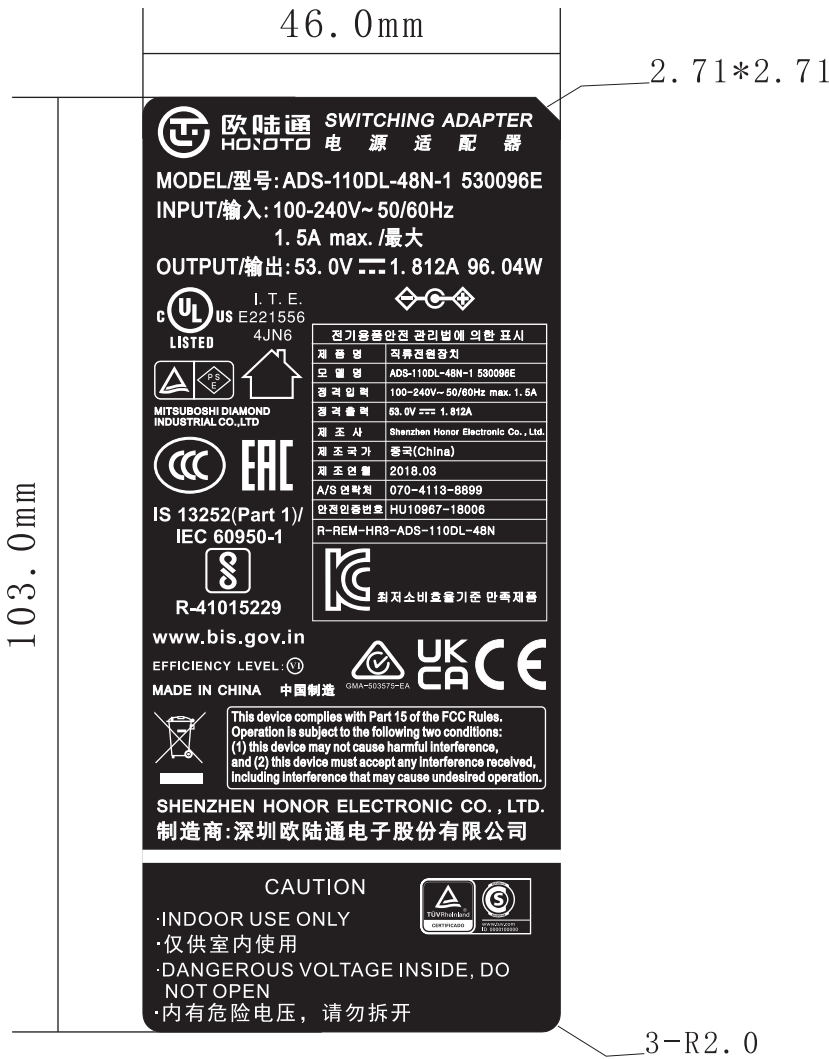

1:1



2018.03

日期码, 随着周期变化
“2018”表示生产年, “03”表示生产月

- Note:
- 1:material quality: 100# PET底格纹+光膜
 - 2:black bottom and white words,clearly
 - 3.one side with glue and stick well
 - 4.temperature-resistant of more than 80 degree
 - 5.straight of sarap edge , without burr, colour and letterform refer to the latest sample.
 6. Be resistant to alcohol smear, without the word out, fuzzy, scratching phenomenon



欧陆通 HONOR ELECTRONIC CO. LTD

TOLERANCES UNLESS NOTED OTHERWISE	DESIGNER	冯晓玲	2022.07.15	DRAWING NAME	LABEL, DESIGNATION
	CHECK			MODEL NO.	
X. :+0/-0.2	APPROVAL			SIZE	DRAWING NO.
XX. :+0/-0.2				A4	
XXX. :+0/-0.3					
ANGLE: ±2°			UNIT mm	SCALE N /S	SHEET 1 OF 1

5-4. Barcode Label

Code 128



7102270HNB17A1X0001

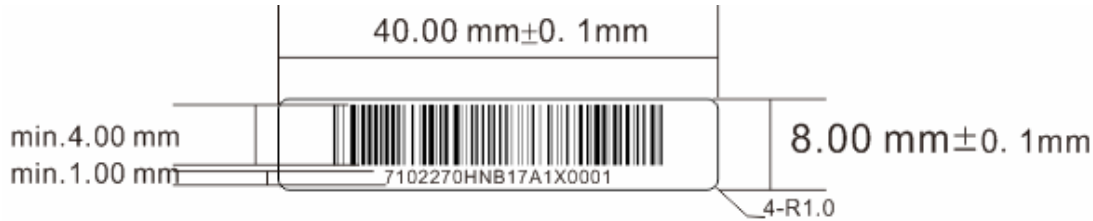
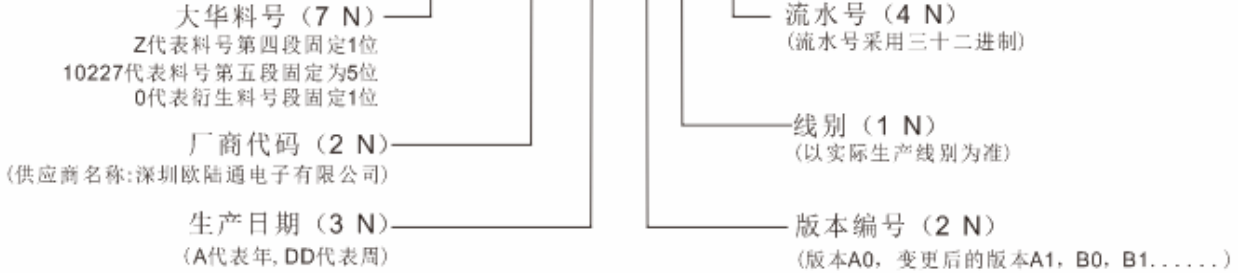

材质: 空白白底PET+透明PET+底格纹+耐擦

代码	名称	注释
Z	大华料号第四段	大华料号第四段固定2位.例如大华料号为: 1.2.19.99.0016. 此处编码为Z, 1.2.19.01.10002,此处编码为1, 1.2.19.02.10003此处编码为2; 以此类推...
XXXXX	大华料号第五段	大华料号第五段固定为5位,若此段为4位,则前面加数字“0”; 例如大华料号为: 1.2.19.99.0016. 此处编码为00016, 1.2.19.01.10002,此处编码为10002, 以此类推...
0	衍生料号段	衍生料号段,若无衍生料号,此处编码为0; 若有衍生料号,取3位衍生料号的后2位;例如1.2.19.17.10026-001, 此处对应编码为A; 1.2.19.17.10005-002, 此处对应编码为B; 以此类推...(由于0和O相同,故O去掉)
HN	供应商代码	深圳欧陆通电子有限公司 (Honor)
ADD	生产日期	A表示年份 (如2017年用A表示,2018年用B表示, 2019用C表示, 按照26个大写英文字母依序排列) DD表示周(如18表示第18周,以此类推...
A0	版本编号	版本编号: 如初始版本A0, 变更后的版本A1, B0, B1...
X	线别	第一位是线别号 (以实际生产线别为准)
XXXX	流水号	流水号4位; 采用三十二进制(0 1 2 - 9, ABCDEFGHJKLMNPRSTUVWXY) 如: 0001, 0002...0009, 000A...000Y, 0010...001Y...YYYY

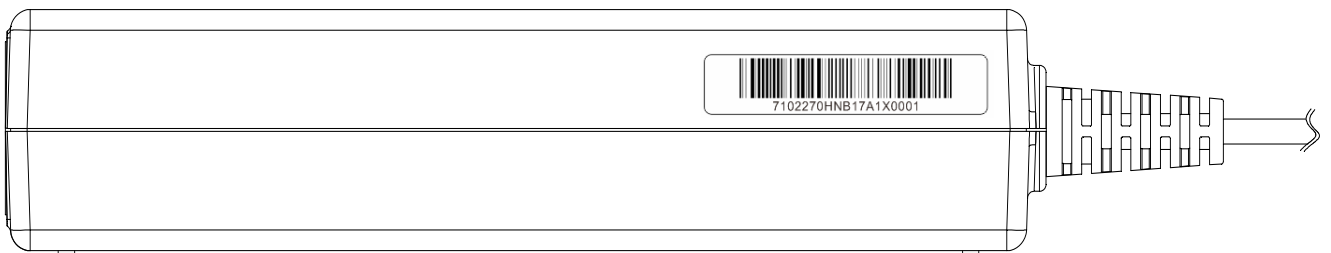

5-5. Packing Drawing

材质:K-K 双坑瓦楞牛皮纸板 (B/C坑)
 耐破度: 11.7kgf/cm² ± 0.5
 边压强度: 4200N/M ± 0.5
 材质:A-A 双坑瓦楞牛皮纸板 (B/C坑)
 耐破度: 7.4kgf/cm² ± 0.5
 边压强度: 3500N/M ± 0.5
 材质:B-B 双坑瓦楞牛皮纸板 (B/C坑)
 耐破度: 5.4kgf/cm² ± 0.5
 边压强度: 2800N/M ± 0.5
 材质:A3A 单坑瓦楞牛皮纸板 (B坑)
 耐破度: 5.0kgf/cm² ± 0.5
 边压强度: 2000N/M ± 0.5
 材质:B3B 单坑瓦楞牛皮纸板 (B坑)
 耐破度: 4.5kgf/cm² ± 0.5
 边压强度: 1800N/M ± 0.5

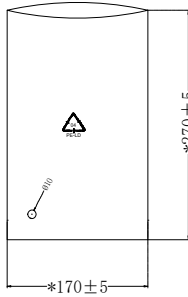
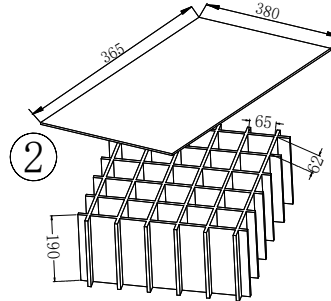
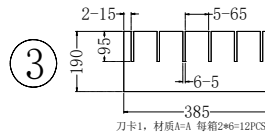
⑤

②

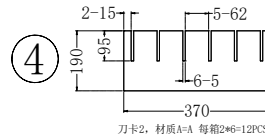
③

刀卡1, 材质A-A 每箱2*6=12PCS

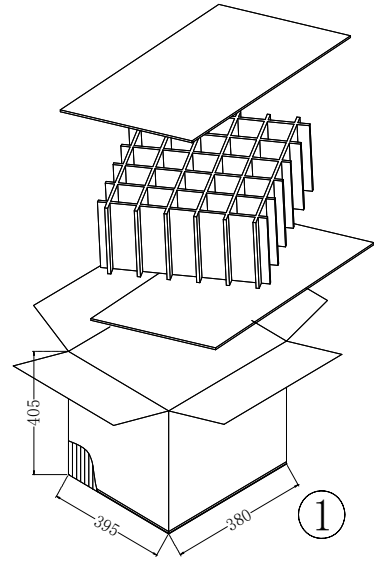
④

刀卡2, 材质A-A 每箱2*6=12PCS

①

单体装PE袋/白盒图

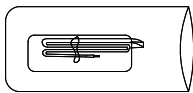

刀卡单格产品放置图

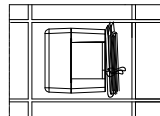

封箱图 “工”字型封胶带

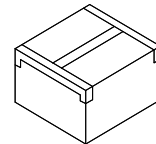

备注:

- 1、材质: 外箱:A-A, 五层瓦楞纸, 厚度:5.0mm Min. (外箱材质可根据订单而改变)
- 2、外观: 光洁, 无污点, 黄白色且无色差, 交接处无裂缝。
- 3、尺寸: 以上尺寸为箱内尺寸, 公差为±5mm。
- 4、数量: 50PCS, (1层装25PCS)分2层装, 3块单坑平板。

5	17917027001R	PE袋	170*270*0.04mm 打一孔(Φ10)	1	PCS
4	17237020001R	刀卡2	370*190 A-A	0.24	PCS
3	17238520001R	刀卡1	385*190 A-A	0.24	PCS
2	17238036501R	平板	380*365 B-B	0.06	PCS
1	17039538003R	外箱	395*380*405 A-A (丝印参考订单)	0.02	PCS
NO.	Part NO.	Name	Specification	QTY	Unit

RevNO	Revision note	Date	Signature	Checked	ECN NO.	SHENZHEN HONOR ELECTRONIC CO., LTD				
						公差(单位/MM): 1. 刀卡/平板: ±2 2. 外箱: ±5 3. PE袋厚: ±0.002 长宽: ±5 4. 白盒: ±3 5. 其它参照图面				
						Model: ADS-110DL-52-1 520094G Modification Name Date Part Name 包材组件 Designed by 骆耀娣 2020.12.26 Part NO Checked by DWG NO Approved by Rev 09 Scale				